



# Technical Manual

## BeNomic Star 300



**Berg Hortimotive**

**Burg. Crezeelaan 42a  
2678 KZ De Lier  
The Netherlands**

**Tel: +31 (0) 174- 517 700**

**Email: [info@berghortimotive.com](mailto:info@berghortimotive.com)  
Internet: [www.berghortimotive.com](http://www.berghortimotive.com)**

## Machine type plate

The BeNomic Star 300 carries a machine type plate which contains the following data: Berg Hortimotive address details, CE marking, serial number and the year of manufacture.

If you would like to contact the Berg Hortimotive dealer with respect to the BeNomic Star 300, please ensure that this information is always readily available.

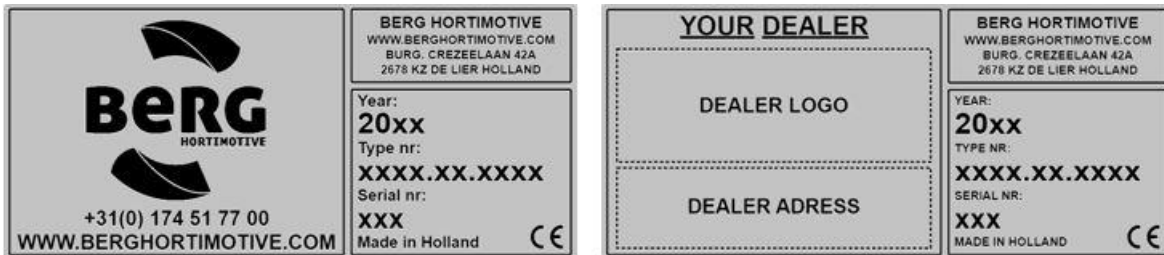

The machine is manufactured by:



Berg Hortimotive

Burg. Crezeelaan 42a  
2678 KZ De Lier  
The Netherlands

Tel: +31 (0) 174- 517 700

Email: [info@berghortimotive.com](mailto:info@berghortimotive.com)  
Internet: [www.berghortimotive.com](http://www.berghortimotive.com)



# 1. Declarations

## 1.1 Copyright

Berg Hortimotive  
De Lier, 2022

No part of this documentation may be reproduced and/or made public by means of print, photocopy, film or any other means without prior written permission from Berg Hortimotive in De Lier, the Netherlands – Except parts intended to be reproduced for the purpose of using this documentation such as abbreviated instructions and indications on the machine.

## 1.2 Liability

Berg Hortimotive is not liable for unsafe situations, accidents and damages resulting from the failure to observe warnings or regulations, as shown on *the BENOMIC 290* and/or in this documentation, for example:

- inexpert or improper use or maintenance;
- use for applications or under conditions other than those specified in this documentation;
- use of parts other than those specified;
- repairs without permission from Berg Hortimotive and/or a certified dealer;
- modifications to the BeNomic Star 300. This includes:
  - changes to the controls;
  - welding, mechanical operations, etc.;
  - extensions or additions to *the* BeNomic Star 300 or the controls.

Berg Hortimotive is also not liable in the following cases:

- if the customer has not fulfilled all his obligations toward Berg Hortimotive (financial or otherwise);
- for consequential damage caused by faults or defects on the BeNomic Star 300 (e.g. business interruption, delays, etc.).

### 1.3 **Guarantee**

Berg Hortimotive guarantee is valid for six (6) months after delivery, and offers the customer warranty on material and manufacturing defects, which arise during normal use. This guarantee shall not apply if the fault(s) is/are due to improper use or causes other than material and manufacture faults, or if Berg Hortimotive supplies materials or used goods after consultation with the client or if the cause of the fault(s) cannot be clearly demonstrated.

The guarantee conditions are described in the Dutch "METAALUNIE" CONDITIONS, as recorded in the most recently deposited text. The terms of delivery will be sent on request. For all goods and materials that Berg Hortimotive does not manufacture itself, Berg Hortimotive does not, at any time, offer lengthier guarantee than that provided to it by its supplier. Warranty is "ex-factory"; faulty machines and/or parts need to be delivered freight-paid.

If machines or installations cannot be delivered, the travel and accommodation costs incurred will be borne by the client.

Goods sold and delivered with factory, importer's or wholesale guarantees shall be subject to the warranty provisions laid down by the suppliers.

The hydraulic pump is subject to manufacturer's warranty only if it has an undamaged supplier's safety seal.

Berg Hortimotive takes responsibility for the availability of replacement parts provided that they are available from its suppliers under reasonable conditions.

## 2. **Foreword**

This manual describes the BeNomic Star 300 .

This manual provides you with additional information on safety aspects, a description of the working principle of the entire setup, as well as maintenance instructions for the BeNomic Star 300.

It will draw attention to potential hazards and directions for avoiding them.

It is very important to read this manual carefully to learn how to operate and maintain the BeNomic Star 300. By reading and following this manual when using *the* BeNomic Star 300, you and others will be helped to properly use the BeNomic Star 300, and to prevent personal injury and damage to the machine.

Berg Hortimotive produces safe machines. These machines are designed to the latest standards, according to the CE marking. The user is responsible for the proper use and maintenance of the machine.

# Table of contents

<b>1. DECLARATIONS</b> .....	<b>3</b>
1.1 COPYRIGHT.....	3
1.2 LIABILITY.....	3
1.3 GUARANTEE.....	4
<b>2. FOREWORD</b> .....	<b>4</b>
<b>3. INTRODUCTION</b> .....	<b>7</b>
3.1 GENERAL:.....	7
3.2 SUPPLIERS INFORMATION.....	7
<b>4. SAFETY</b> .....	<b>8</b>
4.1 DECLARATION OF SAFETY TERMS.....	8
4.2 SAFETY INSTRUCTIONS.....	8
4.3 SAFETY ICONS.....	11
4.4 OTHER RISKS.....	12
<b>5. INTENDED USE</b> .....	<b>13</b>
5.1 SCOPE OF USE.....	13
5.1.1 <i>Physical operating conditions</i> .....	13
5.2 SAFETY SYSTEMS.....	14
5.3 SIGNALLING SYSTEMS.....	15
5.3.1 <i>The battery status indicator (12)</i> .....	15
5.3.2 <i>The buzzer</i> .....	15
5.4 BENOMIC STAR 300 DESCRIPTION.....	16
<b>6. TRANSPORT</b> .....	<b>18</b>
6.1 EXTERNAL TRANSPORT.....	18
6.2 INTERNAL TRANSPORT.....	18
<b>7. COMMISSIONING</b> .....	<b>19</b>
7.1 INSPECTION BEFORE TAKING INTO SERVICE.....	19
7.2 PIPE-RAIL SYSTEM IN HORTICULTURE.....	19
7.3 MINIMUM REQUIREMENTS FOR THE PIPE-RAIL SYSTEM.....	20
7.4 MOUNTING THE FENCE, DOOR AND CONTROL CONSOLE.....	20
7.4.1 <i>Transport frames</i> .....	20
7.4.2 <i>Assembly</i> .....	22
7.5 TILT INDICATION.....	24
7.6 LOAD-HOLDING FUNCTION.....	25
7.7 SCISSOR-LOCKING DEVICE.....	25
7.8 EMERGENCY LOWERING VALVE.....	25
7.9 PIPE - CONCRETE PATH TRANSITION.....	26
<b>8. OPERATION</b> .....	<b>26</b>
8.1 OPERATION.....	27
8.1.1 <i>Undercarriage controls</i> .....	27
8.1.2 <i>Controls on the platform</i> .....	28
8.2 MOVING THE BENOMIC STAR 300 ONTO THE MAIN PATH.....	30
8.3 MOVING THE BENOMIC STAR 300 ON THE HARVESTING PATH.....	30
8.3.1 <i>Driving into the harvesting path</i> .....	30
8.3.2 <i>Driving out of the harvesting path</i> .....	30
8.4 OUT OF SERVICE.....	31
8.5 CLEANING.....	31
8.6 PROBLEMS, CAUSES AND SOLUTIONS.....	32
8.7 DISASSEMBLY.....	34
<b>9. MAINTENANCE AND REPAIRS</b> .....	<b>35</b>
9.1 SPECIALIST MAINTENANCE.....	35

9.2	MAINTENANCE ON, IN OR UNDER THE SCISSOR-UNIT .....	36
9.3	PIPE-RAIL SYSTEM MAINTENANCE .....	37
9.4	CHAIN TIGHTENING.....	38
9.5	CHECK PIPE-RAIL WHEEL WEAR .....	39
<b>10.</b>	<b>TECHNICAL SPECIFICATIONS .....</b>	<b>40</b>
10.1	* EXPLANATION OF THE TECHNICAL SPECIFICATIONS .....	41
<b>11.</b>	<b>EC DECLARATION OF CONFORMITY .....</b>	<b>42</b>
<b>APPENDIX 1:</b>	<b>MAINTENANCE LOGBOOK .....</b>	<b>43</b>
<b>APPENDIX 2:</b>	<b>TECHNICAL DRAWINGS.....</b>	<b>44</b>
<b>APPENDIX 3:</b>	<b>BATTERY SAFETY SHEET .....</b>	<b>45</b>
<b>APPENDIX 4:</b>	<b>CLEANING THE POWDER COAT FINISH .....</b>	<b>50</b>

## **3. Introduction**

### **3.1 General:**

You have made a good choice in purchasing the Berg Hortimotive BeNomic Star 300. You have an excellent tool, which has been carefully constructed and manufactured. This investment will benefit you most if you carefully follow the safety, use, and maintenance instructions detailed in this user manual.

Before commissioning the BeNomic Star 300, please make yourself familiar with this user manual. The safety precautions, instructions and directions given should be observed at all times.

Berg Hortimotive is not liable for damage or indirect damage resulting from failure to follow the instructions and safety precautions set out in this user manual.

The liability of Berg Hortimotive shall also lapse as soon as you or third parties make any modifications to the pipe-rail trolley or accessories without our written permission.

The BeNomic Star 300 has been delivered under the "METAALUNIE" (The Dutch METAL-ASSOCIATION) CONDITIONS, as filed at the court of Rotterdam, as they are in accordance with the last text set out there. The terms of delivery will be sent on request. You can also contact the Koninklijke Metaalunie, Postbus 2600, 3430 GA Nieuwegein, The Netherlands.





### **3.2 Suppliers information**

In the event of breakdowns or defects occurring on the BeNomic Star 300 please contact your Berg Hortimotive dealer.

## 4. Safety

### 4.1 Declaration of safety terms

Safety terms:

- Danger:**  Indicates serious injury or risk of fatality when ignoring the instructions set out in the user manual.
- Warning:**  Indicates risk of injury when ignoring the instructions set out in the user manual.
- Caution:**  Indicates risk of damage to the machine when ignoring the instructions set out in the user manual.
- ATTENTION:**  Indicates risk of injury when ignoring the instructions set out in the user manual.

### 4.2 Safety Instructions

Please read the following safety precautions carefully.  
After reading the safety instructions, always follow them strictly.  
If the safety precautions are ignored, working with the pipe-rail trolley will be significantly more dangerous, which can cause very serious injury.

**DANGER!** 

- **Read the user manual carefully. Follow the instructions, safety precautions, etc. at all times.**
- **The BeNomic Star 300 is suitable for running on a stable pipe-rail system.**
- **Use the BeNomic Star 300 exclusively on the correct type of pipe-rail system. You must check whether the centre-to-centre pipe-rail gauge corresponds with the pipe-rail trolley, see the icon on the platform.**
- **Never exceed the maximum load capacity of 250 kg\* (for capacities and restrictions see 10.1!)**
  - One person incl. load (e.g. tools); see the pictogram on the trolley.
- **Never exceed the sideways applied force of 110 N (towing capacity of 11 kg), during crop maintenance.**
- **Use the BeNomic Star 300 only for crop maintenance in a greenhouse.**
- **It is strictly forbidden to use the BeNomic Star 300 for crop maintenance with a tilt exceeding 2° (linearly and/or crosswise).**
- **It is prohibited to transport any unsecured load with the BeNomic Star 300! Make sure that the load is placed in the middle and is no higher than 40cm above the platform and is always properly secured.**
- **Only one person is allowed on the platform at all times.**



- **Persons are not permitted to ride on the chassis in any way.**
- **It is prohibited to remove the safety fence.**
- **The use of the safety rail height extender is mandatory if the user is taller than 1.80 metres. Only use an original approved Berg Hortimotive safety guardrail raiser!  
(see 5.2)**
- **It is strictly prohibited to increase the lifting height in whatever way.**
  - *Always stand on the work platform.*
- **Keep a safe distance from fixed and/or moving parts of the greenhouse structure, live electric wiring, and cables and ropes.**
- **Pulling steel or other types of rope/cord/wire and installing protective canvas with the BeNomic Star 300 is not permitted.**
- **Using the BeNomic Star 300 as a crane is not permitted.**
- **Persons or pets are not permitted to enter the operational pathway of a BETOMIC S290. Never use more than one pipe-rail trolley on the same path!**
- **All safety shields and protective caps must be fitted and closed during operation of the BeNomic Star 300.**
- **Additional options, accessories and parts must be manufactured and/or supplied by Berg Hortimotive.**

**Warning!**



- **The BeNomic Star 300 may only be operated when there are no other persons, other than the operator, in the vicinity of the machine.**
- **The BeNomic Star 300 may only be operated by persons of at least 18 years of age who have received thorough instruction on the BeNomic Star 300, are familiarized with this user manual, fully understand it, and are aware of the hazards.**
- **The BeNomic Star 300 may only be operated once it has been correctly installed on the pipe-rail system.**
- **All employees working within the active radius of the BeNomic Star 300 must be familiar with the relevant safety rules and regulations that apply to the machine.**
  - *Instructions must be provided by the from the employer.*
- **Repairs on the BeNomic Star 300 may only be carried out by personnel instructed by Berg Hortimotive.**
- **When servicing the scissors, use the scissor-lock at all times (see 9.2).**
- **Never carry out work on the BeNomic Star 300, while someone else is operating it. Always switch it off using the main switch, and remove the charging plug from the trolley before carrying out maintenance.**

- **Check the BeNomic Star 300 every day for defects and give it regular maintenance, see chapter 9: Maintenance.**
- **Clean the controls and safety pictograms regularly.**
  - *Operating functions and safety pictograms must be visible at all times.*
- **The BeNomic Star 300 must always be switched off after use, by using the main switch.**
- **Never leave the BeNomic Star 300 unattended.**
  - *unless the key is removed from the main switch.*
- **It is prohibited to make any modifications/alterations to the BeNomic Star 300 without written permission from Berg Hortimotive.**
- **When leaving a track, first stop and check whether anybody is standing in the direct vicinity before continuing onto the concrete path.**
- **Before going onto a track, ensure that there are no obstacles such as plant remains, etc. lying on the pipe-rail system.**
- **Never clean the BeNomic Star 300 with a water hose, high-pressure water gun or steam cleaner.**
- **When moving the BeNomic Star 300, other than on the pipe-rail, or crossing on a concrete path, the platform has to be at its lowest position.**
- **The BeNomic Star 300 is besides driving on a pipe rail system, also suitable for driving on a flat paved floor (concrete), which is rough enough to be able to drive and stop safely. The surface condition must comply with NEN2743: 2003 Concrete floors.**
- **Never use the BeNomic Star 300 outdoors or on the public road.**
- **It is prohibited leaving a trolley that is not completely at its lowest position.**
- **Follow the battery safety specifications, see Appendix 3.**
- **Beware of feet and toes when operating the lifter on the BeNomic Star 300! The trolley moves a few centimetres forward during the lowering process!**
- **It is mandatory to wear shoes with safety toecaps (minimum S1).**
- **Always remove the charging plug before using the BeNomic Star 300.**

**Attention!** 

- **Keep the workplace tidy.**  
*An untidy working area leads to hazardous situations.*
- **Be focused.**  
*Always maintain the appropriate level of concentration when operating the pipe-rail trolley. Do not operate the BeNomic Star 300 when using medication that could impair your reaction times when operating machinery or participating in traffic.*

### 4.3 Safety icons

The BeNomic Star 300 has the following safety icons. These icons should alert the user to potential hazards or hazardous situations. Take the warnings serious at all times and contact your supplier if the hazard indicated on the icon seems unclear.

Always make sure the icons remain visible and undamaged!

The operator of the BeNomic Star 300 must have read and understood this manual before using the machine. If the user does not understand the warnings in the manual or on the machine (e.g. because he/she speaks a different language), all instructions, hazards, warnings and functions should be explained to the user by a designated person so that the user can clearly understand them.



Used indoors only (in the greenhouse)

Mass of the machine\* in kg

Suitable for the indicated pipe diameter\* with minimum wall thickness

Suitable for the indicated centre-to-centre (gauge)\* pipe-rail system size

Maximum tilt 2°

Maximum lateral applied force in Newton (kg x 10)

Maximum support distance\*

Maximum total load\* in kg (maximum one person + secured load)

Height of the railing depends on the length of the user

**\*The values depend on the type of BeNomic Star 300!**

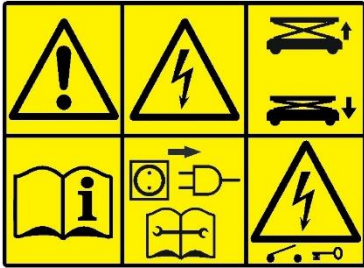

WARNING! Read the user manual before use!

WARNING! During maintenance, first isolate the power (Switch off main switch) and consult the manual

Upwards = scissors up, Downwards = scissors down

Main switch (power): key vertical = ON, key horizontal = OFF

The key can be removed by continuing to turn in the off position.



Pay attention to the lowering platform!

Always use the scissors locking device when working under or on the scissors!



WARNING; danger of entrapment!

Keep your hands away from the scissor parts!



Warning! Dangerous chemical battery: explosive gas and corrosive battery acid!

#### 4.4 Other risks

Despite the best possible design, dangerous situations remain or may arise when using the BeNomic Star 300. Pay extra attention!

- The risk of crushing hands, fingers, arms and head between the scissor parts!
- The risk of crushing under the trolley when using the lifting mechanism for setting down or lifting!
- Tipping of the trolley if used on an unsuitable pipe-rail system!
- Tipping of the trolley if the maximum weight or applied force limits are exceeded!
- Users taller than 1.80 metres can lose their balance if they do not use the obligatory safety rail height extender!

## 5. Intended Use

### 5.1 Scope of use

The BeNomic Star 300 is intended for professional use in the greenhouse horticulture sector. The controls may only be operated by one person with a minimum age of 18 years who has received thorough instruction on operation of the BeNomic Star 300. This person must fully understand the safety instructions and this manual. The BeNomic Star 300 is a pipe-rail trolley, which runs on a pipe-rail system that meets the minimum requirements of paragraph 7.3 and is intended as an aid in harvesting, caring for and/or maintaining the crops in a greenhouse. Use of the BeNomic Star 300 for any other purposes is strictly forbidden. The maximum load may consist of one person plus a secured load, of which the combined weight should not exceed 250 kg\*. The trolley may only be operated once it has been correctly installed on the pipe-rail system. Take extra care when the scissors drop so that no persons or objects are trapped under or between the scissor-unit. Always walk alongside the trolley, therefore not on the chassis when transporting it over the main path.

\* Stability tests have shown that with unfavourable combinations of pipe-rail type and the support distance of the pipe-rail system, constraints must be applied for the maximum permissible load. See 10.1 Explanation of the technical specifications.

#### 5.1.1 Physical operating conditions

Ambient temperature,	
Transport & Storage:	5 to +40 degrees Celsius
Working:	5 to +40 degrees Celsius
Rel. Humidity (RH):	0% to 90%, <u>not condensing</u>
Lighting:	Normal ambient lighting.

The machine is not designed to be used outdoors.  
The machine is not suitable for operating in explosive atmospheres.

## 5.2 Safety systems

The BeNomic Star 300 series is equipped with the following safety systems, which will be described in chapter 7 (Commissioning) and chapter 8.1 (Operation).

- Tilt indication (see 7.5)
- Load-holding function (see 7.6)
- Scissor-locking device (see 7.7)
- Emergency lowering control (see 7.8)
- Pipe-rail to concrete path transition (see 7.11)
- Emergency stop (see 8.1.2)
- Guardrail raisers\*

The regulations for the use of certain safety devices may differ from country to country, always consult the local safety authorities before use, these regulations are authoritative!

- \* The use of guardrail braces depends on the height of the user. For employees taller than 1.80 metres, raising the standard guardrail is mandatory!

- **Always work according to the local safety regulations!**
- **Manipulation of safety systems is strictly prohibited!**
- **Additional options, accessories and parts must be manufactured and/or supplied by Berg Hortimotive.**



### 5.3 Signalling systems

In order to alert the user to changing status of the BeNomic Star 300 during use, a battery status indicator (12) and buzzer are used.

#### 5.3.1 The battery status indicator (12)

The battery status indicator (12) is located on the platform control, for this refer to chapter 8.1.2.

#### Safe & alert status

The battery status indicator (12) displays status off or on

Indication:	Safety status:	Solution:
Off	BeNomic Star 300 is powered off or the emergency stop has been pressed	Release the emergency stop
On	BeNomic Star 300 is on	

#### 5.3.2 The buzzer

The acoustic warning gives the user feedback on the action that is being performed, or a changing safety status.

Buzzer signal:	Action or Safety status:	Status or Solution:
Bleeping	Critical tilt with raised platform	Platform lowered, level the pipe-rail system

#### 5.4 BeNomic Star 300 description

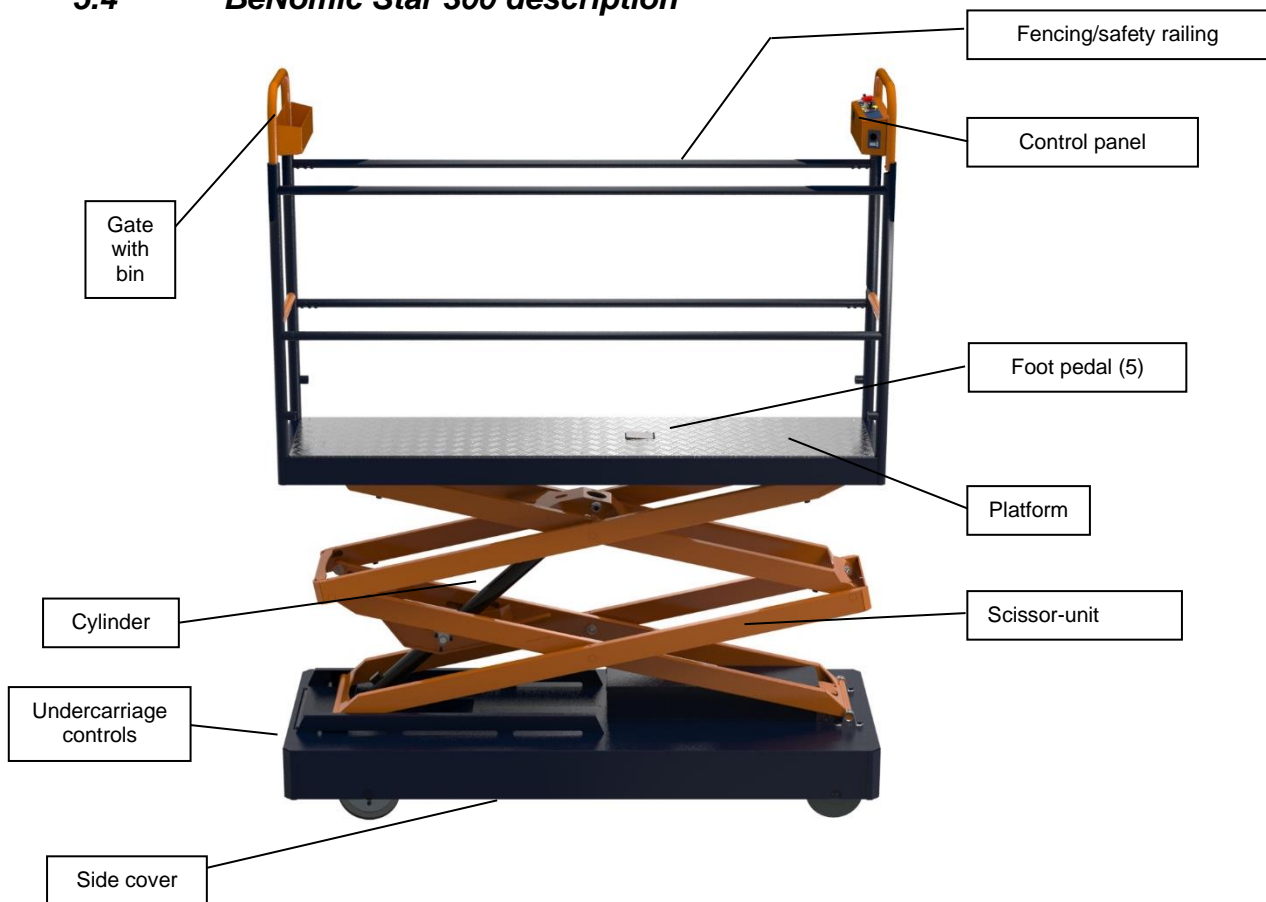

Figure 5.1; Names of the components on the upper-side of the BeNomic Star 300



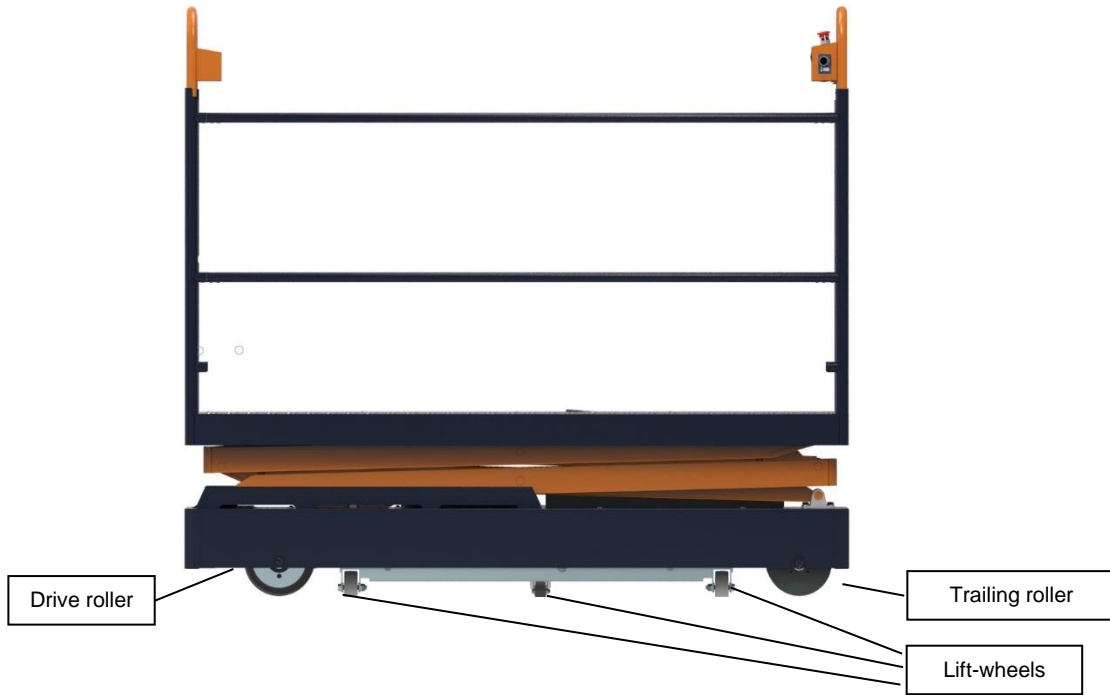

Figure 5.2; Names of the components on the under-side of the BeNomic Star 300

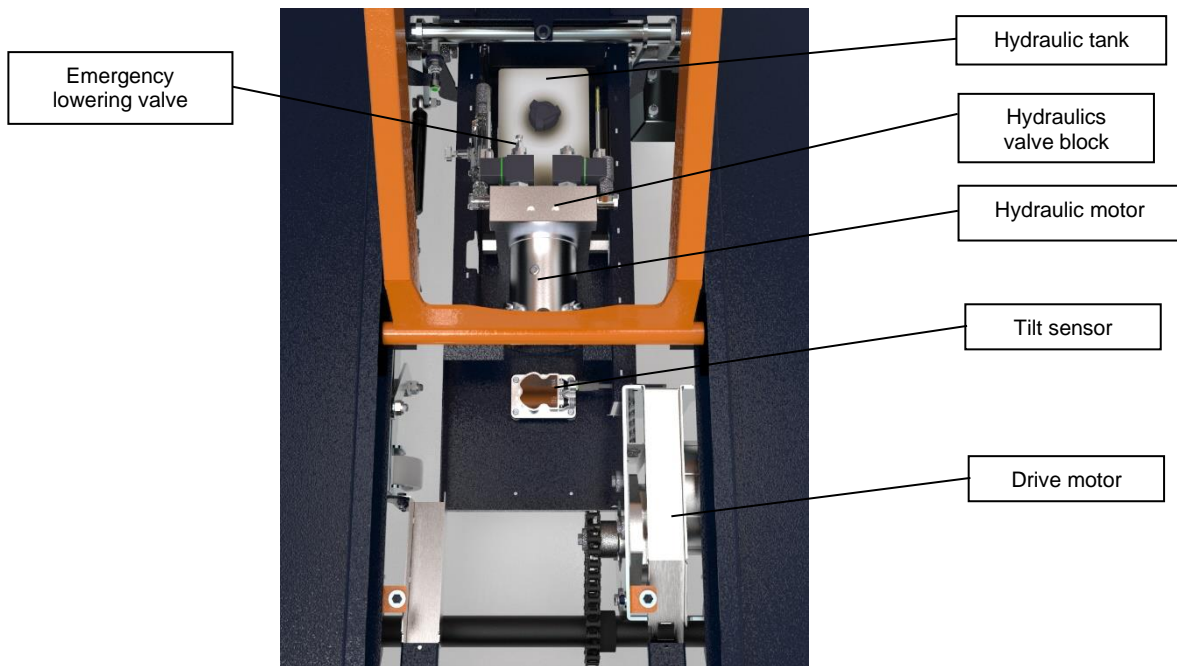

Figure 5.3; Names of the components on the inside of the BeNomic Star 300

## 6. Transport

### 6.1 External transport

Please follow the procedure set out below if you need to transport the BeNomic Star 300:

1. Lower the platform completely.
2. Make sure the lift-wheels are retracted, so that the trolley is resting on its flange rollers.
3. Set the direction and speed control to position 0.
4. Switch off the BeNomic Star 300 with the main switch (turn the red key to the horizontal position).
5. Properly secure the BeNomic Star 300 to prevent it from sliding, rolling or toppling over.
6. Ensure that the BeNomic Star 300 remains dry and frost-free during transportation.
7. After having arrived at its destination, the BeNomic Star 300 must be started up in accordance with the points described in chapter 7.1.

### 6.2 Internal transport

The BeNomic Star 300 may also be transported indoors (in the greenhouse). The preferred method here is to drive the trolley on its lift-wheels (see 8.2), but it can also be moved with a forklift. To move it with a forklift, proceed as follows:

1. Lower the platform fully.
2. The lift-wheels are retracted, so that the trolley is resting on the flange rollers.
3. Switch off the BeNomic Star 300 with the main switch (turn the red key to the horizontal position).
4. Position the forklift forks as far apart as possible and insert them as far as possible under the trolley, keeping them centred.
5. On the other side, check that the forks protrude far enough and are positioned centrally under *the* BeNomic Star 300.
6. Secure the BeNomic Star 300 to the load backrest on the forklift truck, so that the trolley cannot slide or tilt with respect to its position on the forks.
7. Lift the BeNomic Star 300 from the ground carefully, and no higher than necessary.

#### Attention!



- **Secure the BeNomic Star 300 to the rack of the forklift truck with a suitable strap!**
- **Never lift higher than necessary!**
- **Make sure that the forklift truck is suitable for lifting at least 600 kg!**
- **Remove loose parts from the platform before lifting!**
- **Drive slowly and carefully!**

## 7. Commissioning

The BeNomic Star 300 has been specially designed for running on a stable pipe-rail system (see 7.2 and 7.3). Berg Hortimotive checked the pipe-rail trolley for proper functioning and safety before it left the factory. The items described in article 7.1 must be inspected prior to taking the BeNomic Star 300 into service.

### 7.1 *Inspection before taking into service*

The following points must be checked before putting the BeNomic Star 300 into service:

- Mounting the fence, door and control console (7.4)
- No loose electrical connections (all the functions and buttons work properly);
- No damaged cables and/or hoses (leakage).
- The drive and trailing flange rollers and lift-wheels must be undamaged, and they should rotate smoothly;
- The battery should be charged (see Battery indication 8.1.2 No.12).
- Ensure there is no general mechanical damage (with special attention to the scissor components).
- No damage to or impaired visibility of the control components, pictograms and symbols.
- Presence of safety guards and covers.
- The scissor mounting on the undercarriage and the fence on the scissor-lift platform.
- Proper working of the lift-system.
- Battery indicator and buzzer operation as described in Signalling systems (5.3) and Controls (8.1)
- Special attention should be paid to the periodic checks stated in the following paragraphs of this chapter. These checks should be carried out at least monthly or yearly, according to the stipulation!

### 7.2 *Pipe-rail system in horticulture*

The BeNomic Star 300 has been designed to run on a stable pipe-rail system. This means that each path between the crops has a track comprising two pipes of the same diameter with a fixed width between them (centre-to-centre (c.t.c.) size). The pipes are often used as heating pipes and are supported with fixed spacing between them.

### **7.3 Minimum requirements for the pipe-rail system**

Stability tests have shown that with unfavourable combinations of pipe-rail type and support spacing on the pipe-rail system, constraints must be applied for the maximum permissible load. See 10.1 Explanation of the technical specifications.

The BeNomic Star 300 is based on a pipe-rail system as described in the Dutch ARBO catalogue. Briefly, the following key principles apply:

- A pipe-rail system means that each path between the crops has a track comprising two pipes of the same diameter and with a fixed width between them (centre-to-centre (c.t.c.) size).
- The pipes are often used as heating pipes and are supported with fixed spacing between them. These supports are subject to a minimum requirement of a 1.5 mm thick steel base plate (with a stiffening profile), a minimum width of 115 mm and with enough length to ensure that the base plate protrudes at least 70 mm from the two upright supports that carry the pipes.
- The pipes must be steel quality (S235) with pipe diameter and wall thickness of 51/2,25 mm or 45/2 mm respectively.
- The pipes must be anchored into the concrete path. They must not be free-standing!
- Regardless of the pipe-rail system, the requirement is that a maximum support spacing of 1 metre is applied in the last 10 meters!
- At the end of the pipes (in front of the façade), there should be a welded stop with a height of at least 5 cm. These should be checked once for every change of season to ensure that the stops are not flattened, bent, skewed or cracked.
- The surface under the pipe-rail system should be sufficiently load-bearing. This is based on a top-layer cone penetration test value of more than 0.4 Mpa (62 psi). It is important to keep the surface dry, flat and therefore hard. Soft/wet spots must be repaired and any subsidence must be permanently resolved.
- The pipe-rail system must have a maximum tilt of 2 degrees, both lengthwise and width. This makes it important to check the pipe-rail periodically.

### **7.4 Mounting the fence, door and control console**

#### **7.4.1 Transport frames**

In order to reduce transport volumes, the BeNomic Star trolleys may be delivered on special transport frames.

These transport frames are for single use only and must be taken to a recycling company on site.

Berg Hortimotive cannot be held liable for any reuse or use for other applications!



Unstack the BeNomic Star pipe rail trolleys with great caution, following the instructions below:

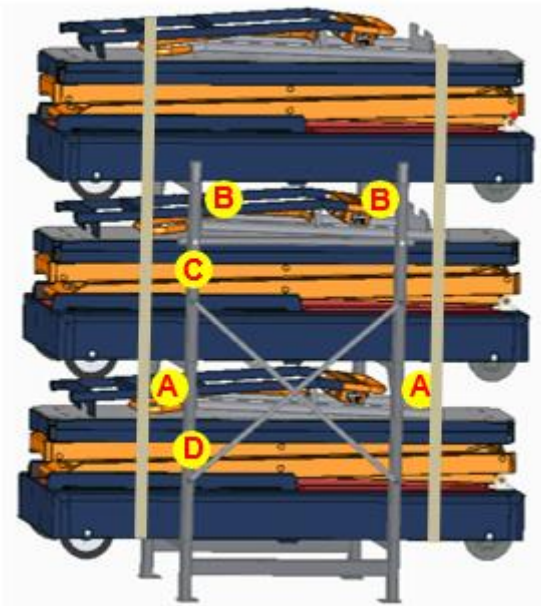

1. Loosen the straps (A).
2. Using the forklift spoons at the marked locations (B), lift the upper BeNomic Star from the transport frame.
3. Lift the second BeNomic Star slightly so that it is released 5cm from the transport frame.
4. Disassemble the upper part of the transport frame (C) and then remove the second BeNomic Star from the frame.
5. Disassemble the middle part of the transport frame (D) and then remove the last BeNomic Star from the frame.

**Attention!**

- Secure the BeNomic Star 300 to the rack of the forklift truck with a strap!
- Never lift higher than necessary!
- Make sure the forklift truck is suitable for lifting at least 1500kg!
- Remove loose parts from the platform before lifting!
- Drive slowly and carefully!



## 7.4.2 Assembly

The local Berg Hortimotive dealer or end user must assemble the guard rail, door and control console before commissioning, following the instructions below:

### Attention!

- Do not put BeNomic Star 300 into operation without assembling the guard rail, the door and the control panel!
- To assemble the guard rail and the door, use only the bolts and screws supplied.



The following mounting hardware is required per pipe-rail trolley:

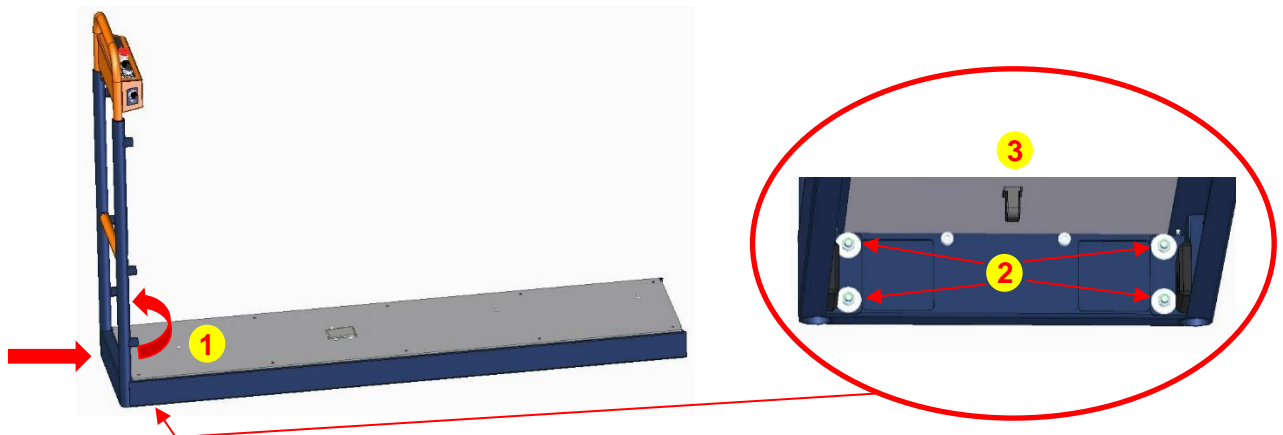
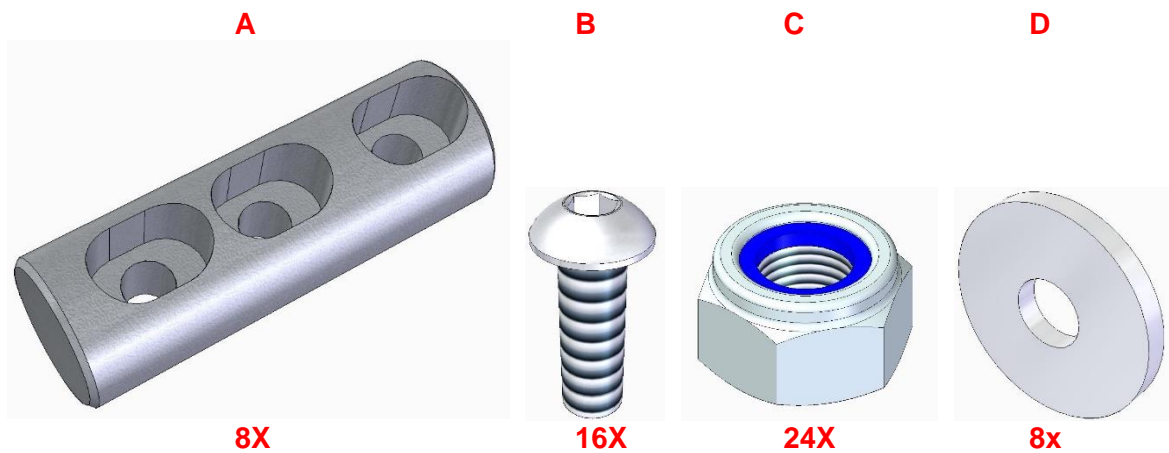

Depending on the chosen transport method, the control panel section will in most cases already have been assembled.

If this is not the case, the assembly process follows the steps below:

1. Fold up the control console railing section and slide the threaded ends into the holes in the platform.
2. Fit the washers (D) and tighten the locknuts (C) under the platform
3. Mount the control cable in the bracket under the platform

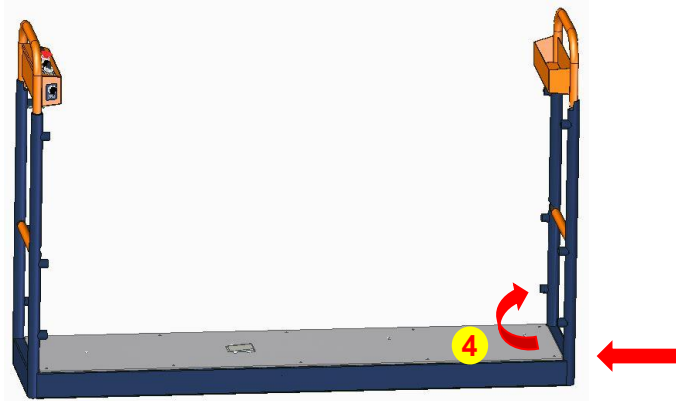

4. Slide the rear fence section with the door into the platform, repeat operation 2. but do **not fully tighten** the locking nuts (C) yet, so that there is still some play to enable the fence tubes to be mounted easily.

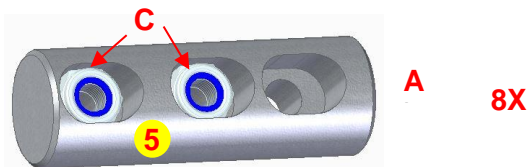

5. Fit the locknuts (C) into the 8 coupling shafts (A) as per the illustration above.

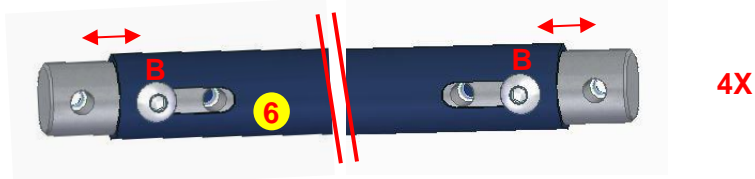

6. Install the 8 coupling shafts in the 4 fence tubes as shown in the illustration above. Do **not fully tighten** the bolts (B) yet, so that the coupling shafts can still slide in the fence tubes.

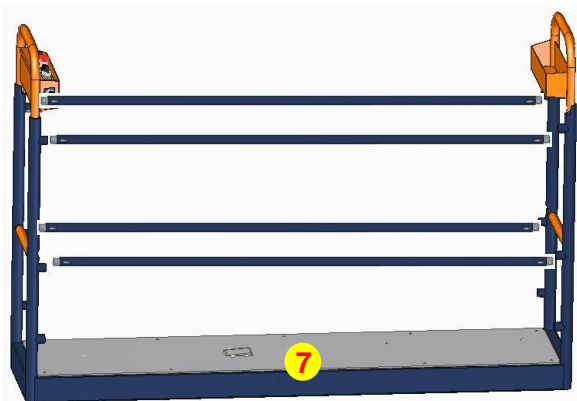

7. Assemble the 4 fence tubes by sliding the coupling shafts (A) into the connecting bushings and securing them with bolts (B), tighten the bolts (B) in the fence tubes as well.

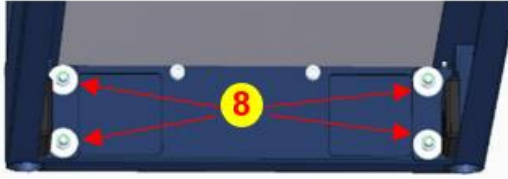

8. Finally, fully tighten the locking nuts (C) of the rear fence section with the door under the platform.
9. After step 8, check one more time to make sure all connections are secure and nothing has been forgotten!

## 7.5 Tilt indication

The BeNomic Star 300 is equipped with a sensor/alarm for both the lengthwise and lateral tilt, with a visual and acoustic warning signal.

For a complete overview of the visual and acoustic warning signals, refer to chapter 5.3.

The operation of the tilt indication should be checked monthly.

Put the BeNomic Star 300 on a flat concrete floor, and operate the platform upwards to about 100 cm, using the scissor-control service button (2) as described in 8.1.1. Then put a pallet jack on one side under the side cover of the BeNomic Star 300, increasing the tilt step by step. During this test, the following signal should be activated:

- The buzzer beeps when the skew is too much.

Establish whether the signal listed above are activated during this check; if so, the tilt indication is approved.

**It is prohibited to work with the BeNomic Star 300 if the tilt indication is not working!**

**Consult your dealer if the tilt indication does not pass the periodic inspection!**

the BeNomic Star 300 reacts in the following manner, if the pipes are not properly levelled;

### **If the platform is higher than 100cm:**

At a critical tilt, the buzzer will beep.

Proceed as follows:

- Lower the platform
- The buzzer stops beeping
- Drive back until the BeNomic Star 300 is properly levelled again
- Follow the recommendations below immediately

### **Follow-up action after exceeding the tilt:**

The pipe rail system must be levelled before work may be resumed. First test the prepared piece of rail by driving over it with the platform in the lowest position, at low speed. If this gives no problems, test a second time with the platform raised and at minimum speed. If no problems occur, normal operations can be resumed. Make sure you have a solid and durable solution to the skew of the rails! **Use a sound and sustainable solution for resolving misalignment of the rails!**



**If the platform is lower than 100cm:**

The skew detector is disabled if the platform is lower than 100cm.

In case of a critical misalignment the buzzer will not beep.

If the employee himself experiences a critical misalignment, it is necessary to carry out the 'follow-up action after tilt indication'.

**Caution!**

**By taking this preventive action, a dangerous situation in the future is prevented.**



**7.6 Load-holding function**

If the hydraulic hose is punctured when using the work platform in the raised position, the 'load-holding function' will immediately operate. The work platform stops lowering, after which the operator has to drive it back to the main path slowly. Stay calm, get help, and contact your dealer.

**7.7 Scissor-locking device**

In order to be able to perform work and maintenance safely when the work platform is raised, the scissor-locking device must always be fitted. For this, see chapter 9.2.

**7.8 Emergency lowering valve**

The emergency lowering valve is located under the cover plate, which is under the scissor structure at the location of the yellow sticker shown below.



If the scissors no longer go down with the controls on the platform (9) and not with the controls on the leading edge of the BeNomic Star 300 (2), the emergency lowering valve lever must be put in the direction of the arrow.

**Beware of trapping your hands, arms or head between the scissors parts or under the platform!**

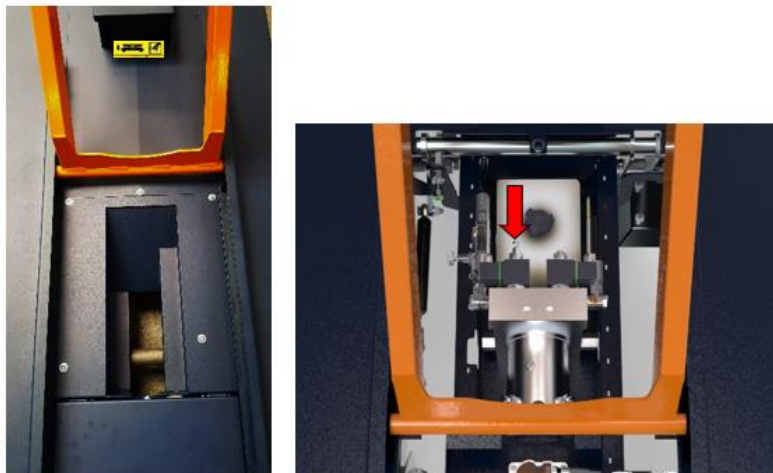

*Fig. 7.1; Illustration of the emergency lowering valve control*

**Attention!**

**Beware of trapping your hands, arms and head between the scissors parts or under the platform! Use this function only in an emergency!**



## 7.9 Pipe - concrete path transition

When approaching the concrete path from the pipe-rails, the operator must stop the BeNomic Star 300 in time and lower the platform. It is necessary that the operator knows when the concrete path is approached in order to reduce speed and stop in time. See also 8.3.2.

**Attention!**

**Moderate speed when approaching the concrete path, Beware of bystanders!**



## 8. Operation

Make sure that you are familiar with the BeNomic Star 300 and its controls. Make sure that the person operating the BeNomic Star 300 has received instructions regarding the pipe-rail trolley and its safety precautions, and has read and understood this manual.

- The BeNomic Star 300 may only be operated if one is sure that no one is in the immediate vicinity of the pipe-rail trolley.
- Before use, remove crop remains and other waste or obstacles from the pipe-rail system.
- Keep the BeNomic Star 300 clean, and regularly remove dirt accumulations. To clean the vehicle, turn it off by removing the key from the ignition.
- After using the BeNomic Star 300, remove the key from the ignition switch.
- Maintain the BeNomic Star 300 regularly and place it in a dry, frost-free place if it is not used for a longer period.

**Charge the batteries if only 1-2 orange LEDs illuminate on the battery status indicator. If this level is reached during work activities, you can usually continue until the end of the day. If the last orange LED starts flashing, the battery is in a low state of charge, complete the work in the harvest path and follow the advice for charging the battery below. If only the red LED lights up and the speed decreases, the BeNomic Star 300 should be charged immediately. Charging must not be interrupted until the charge indicator shows that it is fully charged, after approximately 12 hours. (See the battery charger manual for this). Brief charging during coffee and lunch breaks must be avoided as this can cause serious damage to the batteries. Charging too soon (when the battery status indicator has more than three orange LEDs) will result in a shorter battery lifespan because the batteries wear with each charging cycle, avoid unnecessary charging!**

**Explosive gas is released when the batteries are being charged. Keep sparks, naked flames or cigarettes away from batteries. Ensure that the place where batteries are charged and/or stored is well ventilated. Ensure that no metal objects can fall on the batteries as this could cause short circuits or sparks which in their turn could lead to an explosion.**



## 8.1 Operation

### 8.1.1 Undercarriage controls

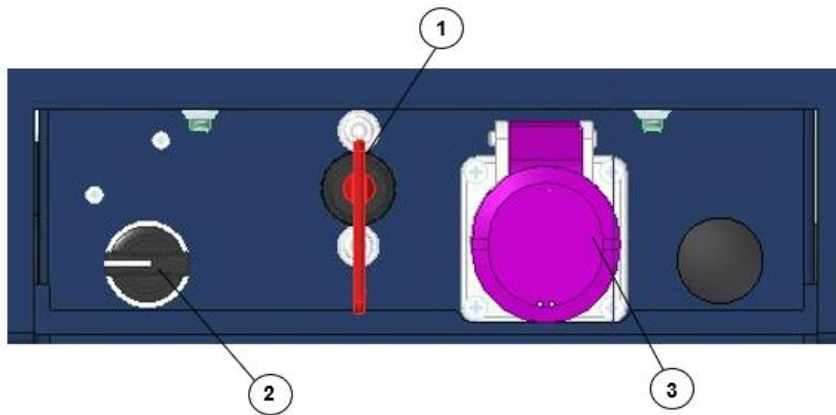

Figure 8.1; Controls on the BeNomic Star 300 undercarriage

#### 1. MAIN SWITCH / EMERGENCY STOP

The BeNomic Star 300 can be switched on and off with the main switch. If the red key is turned into the running position (vertical), then the trolley is ON, if the red key is turned into the perpendicular of the running position (horizontal), then the trolley is OFF. The battery status indicator will light up (see Platform Controls 8.1.2). When the BeNomic Star 300 is not being used or charged, the red key should be taken out of the ignition. The main switch also serves as an emergency stop. If the key is positioned horizontally, the trolley is completely switched off.

#### 2. SCISSOR-CONTROL SERVICE BUTTON

The scissor-control selector switch allows the platform to be raised or lowered without standing on it. The BeNomic Star 300 should not be on the pipe-rails for this operation! Turn the service button (2) clockwise (white stripe up) and the platform will rise as long as the button is operated. Turn the service button (2), white stripe downwards, and the platform will lower as long as the button is operated.

#### Attention!



- The service button is intended only for trained technical personnel for periodic maintenance! Any other use is prohibited!
- Ensure that no persons or objects can get under or between the scissors construction while lowering!
- Provide adequate space above the BeNomic Star 300 to allow the scissors to go up!
- Do not use the service button if anyone is on the platform!

#### 3. CHARGING PLUG SOCKET

You can use this socket to charge the batteries. Make sure the plug is removed before the BeNomic Star 300 is put into operation! *Always remove the charging plug during maintenance.* Only a suitable charger should be used - see the specifications on the charger.

#### 5. FOOT PEDAL

A foot pedal (5) is mounted in the platform (page 16), the BeNomic Star 300 will run in the desired direction (6) for as long as the foot pedal is operated.

## 8.1.2 Controls on the platform



Figure 8.2; Top control consoles

### 6. DIRECTION OF TRAVEL REVERSE SWITCH

The direction of travel selected is determined by setting the selector to the desired direction.

### 7. SPEED CONTROL KNOB

0 = idle 10 = maximum speed

### 8. EMERGENCY STOP

Only use in case of emergency! The main switch (1) must be used for switching off.

- Press = stop
- Turn-pull out = release

In the event of an active emergency stop (pressed), all functions of the BeNomic Star 300 will stop immediately and the battery condition indicator (12) will switch off.

### Starting up after engaging the emergency stop



Never release an emergency stop (reset) if you do not know who engaged the emergency stop and why.

Release the emergency stop only when the dangerous situation has been averted!

## 9. WORK PLATFORM DOWN/UP, ROTARY SWITCH

The rotary switch can be used to lower or raise the work platform. The platform will lower as long as the knob is turned counter-clockwise.

**Beware of people or objects in the vicinity of the scissors while lowering!**



The scissors will rise to a maximum platform height as long as the rotary switch is turned clockwise, pointing upwards. The maximum height is 3 metres.

Release the button as soon as the work platform has reached the maximum height!

## 10. & 11. HYDRAULIC LIFTING OF THE TROLLEY

Pressing these buttons (1x) results in the complete lifting or lowering of the BeNomic Star 300, after which it can be turned and moved manually.

The pushbutton on the right hand side (11) is for extending the lift. (raising the carriage)

The push button on the left side (10) is for retracting the lift. (trolley down)

### Attention!

- Only lift the machine on a flat surface (on the concrete floor or on the main path), never lift it on the pipe-rail system or on a concrete floor with a slope!
- Fully lower the platform before lifting the BeNomic Star 300!
- Beware of toes and feet when lowering the BeNomic Star 300!



## 12. BATTERY STATUS INDICATOR



The battery status indicator shows the status of the batteries. If all LEDs light up, then the battery is fully charged, the battery charge is proportional to the number of LEDs that light up. The LEDs are coloured Orange and Red. When all the Orange LEDs are on, the batteries are charged 90 to 100%, for each Orange LED that goes out, approx. 10% battery power has been consumed. Charge the batteries if only 1-2 Orange LEDs light up on the battery status indicator. If this area is reached during work activities, then work can usually continue until the end of the day. When the last Orange LED starts flashing, the battery empty status is about to come into operation, complete the work in the harvesting path and follow the advice for battery charging given below. If the Red LED is illuminated, the BeNomic Star 300 should be recharged immediately. The speed is automatically reduced. Switch the BeNomic Star 300 off with the main switch and charge the battery without interruptions for at least 12 hours until the battery charger indicates full. (consult the battery charger's user manual!)

Avoid charging before the battery status indicator indicates 50% discharge (3–4 Orange LEDs). Always try to match the approx. 20% discharge status (1–2 Orange LEDs). This has the following advantages:

- Reduced number of charging cycles, improves the service life
- Less water use
- Less energy use

If the battery status indicator LEDs flash, then the BeNomic Star 300 is being recharged without it being switched off using the main switch. Turn off the BeNomic Star 300 and wait until the battery charger automatically stops charging, the batteries are then fully charged!

**Regardless of the level of usage, charge the batteries at least once a month using a suitable charger! Avoid deep discharge of the batteries, this causes severe damage and shortens the life!**

**See also the instructions contained in Appendix 3 Battery safety sheet!**

## **8.2 Moving the BeNomic Star 300 onto the main path**

Press button (11); the BeNomic Star 300 will now be supported its lift-wheels. The BeNomic Star 300 is easy to manually turn and move sideways.

### **Attention!**

- **Never leave the BeNomic Star 300 unattended on its lift-wheels.**
- **Always walk next to/behind the trolley!**
- **Take care with ramps and trenches, and reduce speed!**
- **Moving the BeNomic Star 300 on the on the flange rollers is prohibited!**



## **8.3 Moving the BeNomic Star 300 on the harvesting path**

The speed selected in the harvesting path is one that best suits the work. (See Appendix 3 *Efficient use of the pipe-rail trolley*)

The BeNomic Star 300 will move in the desired direction as long as the foot pedal is operated.

While driving, keep an eye on the position relative to the beginning and end of the harvesting path, moderate the speed and stop in time!

### **8.3.1 Driving into the harvesting path**

Position the BeNomic Star 300 straight in front of a harvesting path and drive it completely onto the pipe-rails. When necessary, raise the work platform to working height using rotary knob (9) afterwards.

### **Attention!**

**Always use the appropriate recommended personal protective equipment (PPE)! (see 5.2 Safety Systems)**



### **8.3.2 Driving out of the harvesting path**

When approaching the concrete path, reduce speed in time and the operator should stop driving. Lower the working platform completely and activate the foot pedal to drive onto the concrete path. It is recommended when crossing the main path to do this only in the lowest position!

Cross or move the BeNomic Star 300 to another harvest path as described in section (8.2).

## **8.4**      ***Out of service***

If the BeNomic Star 300 is out of service, make sure the platform is in the lowest position and the lift-wheels are retracted. The trolley stands now on its flange rollers. Always switch off the machine, using main switch and remove the key. Store it **with charged batteries** in a moisture-free and frost-free room. It is recommended to connect the batteries on the BeNomic Star 300 to a trickle charger. Otherwise, the batteries should always be charged at least monthly (even if the BeNomic Star 300 remains stationary for a long time). Provide a levelled surface and protect the trolley from direct sunlight. If the BeNomic Star 300 is put back into operation after a longer period in storage, it must first be inspected as described in section 7.1 (Inspection before starting operations).

## **8.5**      ***Cleaning***

Regularly remove any remains of plants, leaves, etc. and brush off any sand and dust. Clean the pipe-rail trolley with a dry/damp cloth and soft brush. If it is dry, you may clean the BeNomic Star 300 with compressed air. Never pour water over the BeNomic Star 300 and/or clean the machine using a steam or high-pressure water cleaner, as this can cause serious damage to the electrical circuits. Every week, remove sand and dirt from the frame at the level of the scissor-slide blocks. See also Appendix 4. Cleaning the powder coat finish

## 8.6 *Problems, causes and solutions*

The BeNomic Star 300 is equipped with various safety systems that can temporarily block the intended functions, for example through incorrect operation.

In order to alert the user of a changing status or incorrect operation of the BeNomic Star 300 during use, a battery status indicator (12) and buzzer is activated. If any of the situations below occur, first always refer to chapters 5.3.1 and 5.3.2!

### **Problem A : The BeNomic Star 300 does not run.**

- Cause** : **Key switch is disabled**  
**Solution** : *Enable key switch (vertical)*
- Emergency stop locked**  
*Release emergency stop (turn/pull out)*
- Speed potentiometer at 0**  
*Set a speed*
- Motor controller fault**  
*Switch off and on again with the main switch*  
*Consult your dealer*
- Battery terminals make poor contact**  
*Clean the battery terminals, remount the clamps*
- Defective foot pedal**  
*Replace foot pedal, consult your dealer*
- Lifter not withdrawn far enough or sensor defective**  
*Withdraw lifter (system) fully (10) or check sensor*
- 25A circuit breaker in 0-position**  
*Consult your dealer*
- 6.3 A control circuit fuse defective.**  
*Consult your dealer*

### **Problem B : Speed can be poorly adjusted.**

- Cause B** : **Speed control button is defective.**  
**Solution** : *Consult your dealer*
- Drive motor control is defective**  
*Consult your dealer*



---

**Problem C : The work platform will not raise/lower.**

---

- Cause C :** **Lift-system sensor not activated/defective**  
**Solution :** *Withdraw lifter system fully or check sensor*  
**Batteries empty** (Red LEDs on battery status indicator)  
*Charge batteries*  
**Battery terminals make poor contact**  
*Clean the battery terminals, remount the terminals*  
**Key switch is off**  
*Enable key switch (set vertical)*  
**Emergency stop pressed**  
*Release emergency stop (turn / pull out)*  
**Overloaded**  
*Reduce load. (see 10. Specifications)*  
**insufficient hydraulic fluid**  
*Replenish hydraulic fluid (scissors up, supplier information)*  
**Switch/button faulty**  
*Try the scissor-control service button next to the main switch*  
**80 A fuse defective.**  
*Consult your dealer*  
**6.3 A control circuit fuse defective.**  
*Consult your dealer*

---

**Problem D : The lifter system won't go out/in.**

---

- Cause D :** **The work platform is too high**  
**Solution :** *Lower the work platform to the lowest position*  
**Batteries empty** (Red LEDs on battery status indicator)  
*Charge batteries*  
**Battery terminals have poor contact**  
*Clean the battery terminals, remount the terminals*  
**Key switch is off**  
*Enable key switch (set vertical)*  
**Emergency stop pressed**  
*Release emergency stop (turn / pull out)*  
**Insufficient hydraulic fluid**  
*Replenish hydraulic fluid (scissors up, supplier information)*  
**Switch/button faulty**  
*Try the scissors control service button next to the main switch*  
**80 A fuse defective.**  
*Consult your dealer*  
**6.3 A control circuit fuse defective.**  
*Consult your dealer*

---

### **Problem E : The BeNomic Star 300 has overturned.**

**Cause E** : - **Carelessness with the forklift truck**  
- **Unstable pipe-rail system**  
- **Excessive applied force**  
- **Overloaded**  
- **Tilt detector ignored**  
- **Have run into a path next to the pipes**  
- **Lifting on uneven surface**

**Solution** : 1. *Switch the trolley off*  
2. *Set the trolley upright*  
3. *Remove covers*  
4. *Disconnect the batteries*  
5. *Clean the trolley*  
6. *Observe the damage*  
7. *Find the cause and provide a sustainable solution*  
8. *Check according to chapter 7*

**!!!BEWARE of liquids, battery acid is very corrosive!!!**

## **8.7 Disassembly**

If your BeNomic Star 300 has become so worn and defective that it must be dismantled, you must take it to your supplier or another company that specialises in dismantling vehicles. Never take your BeNomic Star 300 to a scrap metal merchant or dump. The BeNomic Star 300 must be dismantled and chemical parts (hydraulic fluid and batteries) must be disposed of correctly.



Deposit defective batteries at your municipal dump or your supplier.  
Dispose of oil/fluid as chemical waste.



## 9. Maintenance and repairs

The BeNomic Star 300 is a very high-quality product. The following maintenance instructions must be strictly followed to safeguard its quality. Repair and maintenance work must be recorded in the maintenance logbook (see Appendix 1). The employer is also responsible for periodically checking tools and equipment according to the current Working Equipment Guidelines.

Before starting maintenance, switch off the BeNomic Star 300 using the main switch.

Maintenance - Checks	Tools	Daily	Weekly	Monthly	Yearly
Sufficiently charged battery (see 8.1.2 (12))	Battery status indicator	X			
Damage to control components	Visually	X			
Damage to/visibility of pictograms and stickers	Visually	X			
Cleaning the foot pedals + platform	Brush / Damp cloth		X		
Cleaning the control panel	Brush / Damp cloth		X		
Clean the frame and scissor-slide blocks	Brush / Damp cloth		X		
Check for leakage, and damaged cables and hoses	Visually		X		
Check for ingrained dirt or string wrapped around wheels and chain	Visually		X		
General mechanical damage	Visually		X		
Lifting and lowering movement – check for jerkiness (low hydraulic fluid level)	Hydraulic fluid ISO Viscosity Grade 46		X		
Charge batteries when necessary, and at least once per month (see 8.1.2 (12))	Battery charger			X	
Check battery fluid levels (plates should be 1 cm below the fluid level, see Appendix 3)	Distilled water, gloves and glasses			X	
Check that the tilt signal is operating correctly	Test > 2 degrees			X	
Check for leaks on hydraulic components (pump/valves) under the cover	Tool to remove bolt from the cover			X	
Check pipe-rail wheel wear (see 9.5)	Visually			X	
Grease the hoist wheels, drive chain and ball bearings	Ball-bearing grease, chain lubricant or another universal lubricant			X	
Check chain tension (see 9.4)	Open-ended spanner			X	
Cap mountings on the scissor-shafts	Visually			X	
Grease the hinged parts of scissor-unit (see 9.2)	Grease gun and grease				X
Grease the hinged parts on the lift-system	Spray grease/lubricating grease				X
Check welds on the scissor-unit for cracks (hairline) and rust	Visually				X

If the above checks show that there is a defect on the BeNomic Star 300, contact your BeNomic Star 300 dealer immediately. Operating the trolley, when defects are found, can be very dangerous and is strictly forbidden!

### 9.1 Specialist maintenance

Maintenance and repairs to the items listed below, may only be carried out by approved Berg Hortimotive dealers:

- Work on electrical components/wiring, (excluding foot pedal exchange)
- All work on the hydraulic system.
- All work concerning the drive motor and the reducer unit (excluding cleaning, readjustment or replacement of the chain and chain-sprockets).

## 9.2 Maintenance on, in or under the scissor-unit

For maintenance work on, below or between the scissors construction, the separate scissor-locking device should be fitted.

Do this in the following way:

1. Set the platform at the required height with the service button (2)
2. Attach the scissor lock to the shaft under the platform (A)
3. Attach and fix the height adjustment bolt (B) at the desired height
4. Lower the platform (C) using the service button (2) until it is in the locked position
5. Switch off the BeNomic Star 300 with the main switch (1).

After maintenance, the above actions are carried out in reverse order and the BeNomic Star 300 is again ready for use.



Figure 9.1; Using the scissor-lock

The scissor shafts run on bearing bushes. The inner-parts of the scissors are connected to the outer ones with a shaft. To prevent rust on the shafts, lubricate them with a universal lubricant, by using a grease gun at least once annually. Raise the scissors and block the unit using the scissor-lock (see figure 9.1). Put the grease gun on the nipples (see figure 9.2) and pump in grease until it comes out at the ends of the bearing bushes.

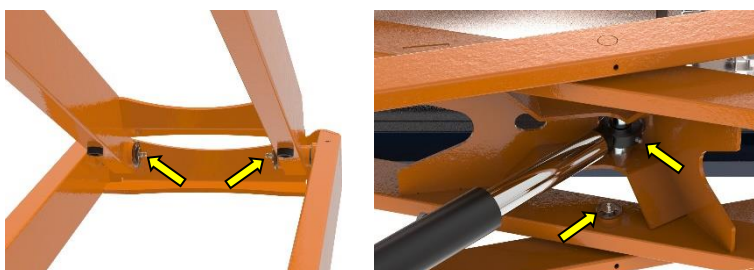

Figure 9.2; Position of the scissor shafts and cylinder rod head grease nipples

### **9.3**      ***pipe-rail system maintenance***

The pipe-rail system on which the BeNomic Star 300 runs should be checked on a regular basis. The BeNomic Star 300 has been designed to run on a stable pipe-rail system. This means that each path between the crops has a track comprising two pipes of the same diameter with a fixed width between them (centre-to-centre, c.t.c. size). The pipes are often used as heating pipes and are supported along fixed distances.

Stability tests have shown that with unfavourable combinations of pipe type and support spacing on the pipe-rail system, constraints must be applied for the maximum permissible load. See 10.1 Explanation of the technical specifications.

The pipes should be secured on the concrete path and cannot be loose. Regardless of the pipe-rail system, our requirement is that a maximum support distance of 1 metre is applied in the last 10 meters! At the pipe ends (in front of the façade) there should be an end-stop welded on that is at least 5 cm in height. At the end of each season check whether the stops are not flat, folded, crooked or broken. The ground under the pipe-rail system should be dry, flat and hard. Soft or damp spots should be repaired and surface indentations permanently repaired.

Additional information can be found in chapter 7.3: Minimum requirements for the pipe-rail system.

## 9.4 Chain tightening

The chain tension should be approximately 1 cm. If it is not, proceed as follows:

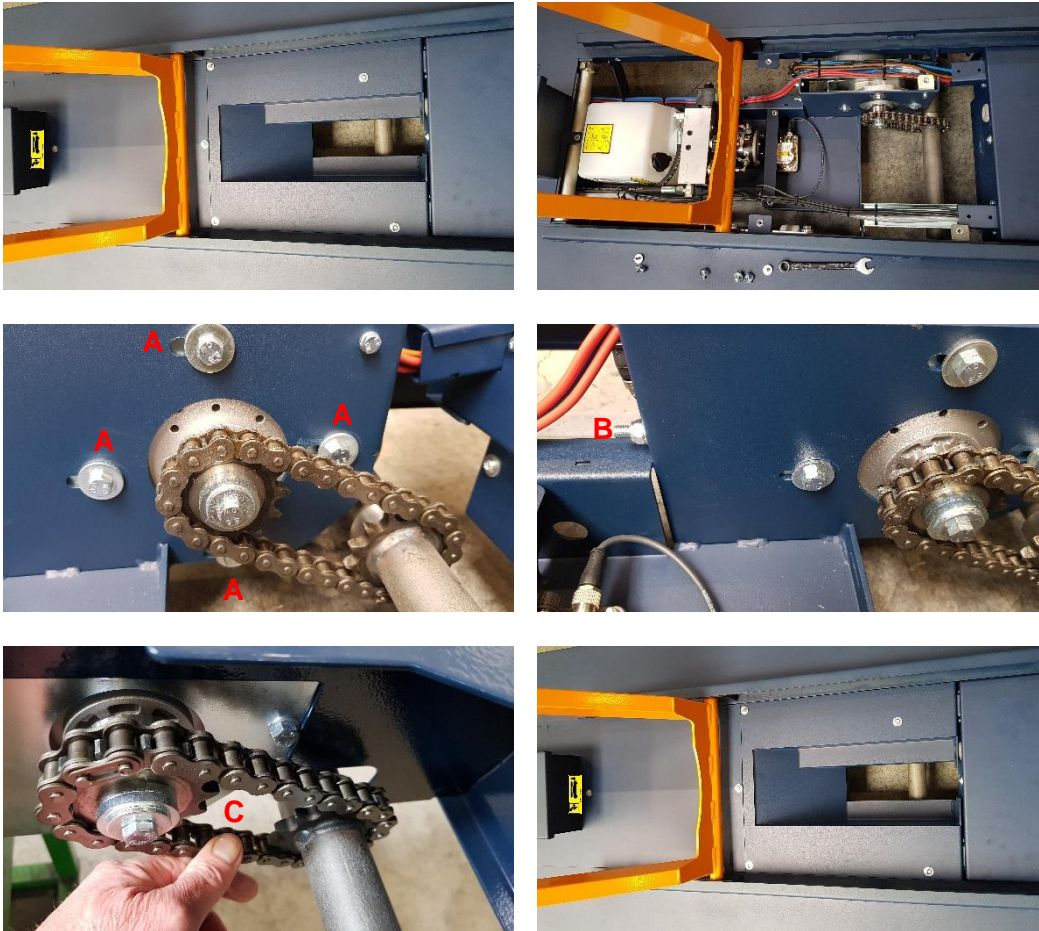

Figure 9.5: Chain tension

1. Turn off the BeNomic Star 300 with the main switch and remove the key from the ignition to prevent the BeNomic Star 300 from being enabled.
2. Remove the covers.
3. Loosen the four motor mounting bolt (A) a little.
4. Tighten the chain by tightening the adjustable lock nut (B).
5. The chain slack should be about 1cm (C).
6. Tighten the motor mounting bolts (A) again firmly.
7. Mount the cover caps.

## 9.5 *Check pipe-rail wheel wear*

Every running surface of any material is subject to wear.

The material of the flange rollers has the following favourable characteristics:

- Flange rollers are silent
- Rolling resistance is low
- Lower load for the heating pipes
- Acceptable durability

With this information we want to indicate when it is time to proceed with replacing the flange rollers.



Wear is approx. 1 mm; the rollers have been in use for some time.

Normal maintenance, inspection for run-in string.



Wear is 2-3 mm; the rollers are still fine.

Normal maintenance, inspection for run-in string.  
Roller replacement not yet necessary.



Wear is 5 mm or more. The roller has flat sides and has been blocked.

Replacement is now necessary!  
Consult your dealer.

## 10. Technical Specifications

Type:	5810.xx.xxxx
Dimensions [mm]:	2 scissors Star 300
C to C dimension*	425 - xxx
Length	2000
Width / c to c - c to c	
425-450	636
475-550	736
575-600	786
650-700	886
750-800	986
Wheelbase [mm]	1565
Undercarriage step-up height from a concrete path	263
Step-up height to platform in lowest position of chassis step	287
Control panel height from platform	1112
Length of work platform	2000
Width of work platform	460
Max. work platform height*	2900
Max. Load capacity [kg]	250
Max. lateral pressure [N]	110
Weight [kg] (c-to-c 550)	400
Motor power [kW]	0.25
Motor power [kW]	1.2
Hydraulic system pressure [bar]	200
Hydraulic fluid, viscosity 46 [L]	2.2
Max. speed on rails [m/min]	60
Max. lifting speed [m/sec.] #	0.17
Max. lowering speed [m/sec] # (# at 80 kg load)	0.12
Voltage [Volt DC]	24
Battery capacity [Ah] (5h/20h)	120/159
Vibration level [m/sec <sup>2</sup> ]	<0.5
Noise level [dB]	<70



### 10.1 \* Explanation of technical specifications

Stability tests have shown that the following restrictions must be applied with unfavourable combinations of: pipe-rail type and support spacing on the pipe-rail system.

- A: Pipe diameter
- B: Pipe rail system center to center measurement (track width)
- C: Bracket distance
- H: Platform height

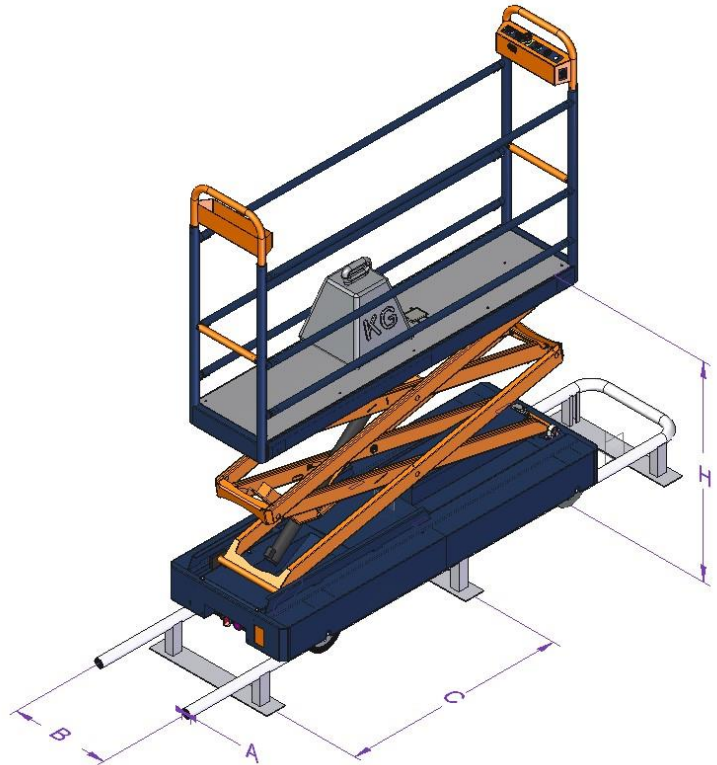

A = 45 mm			
B =	≤ 52 cm	> 52 cm	
C =	Max. 1.25 metres		
H =	2.5	X	150 kg
	2.9	X	
<b>Not recommended by Berg Hortimotive</b>			

A = 45 mm			
B =	≤ 52 cm	> 52 cm	
C =	Max. 1 metres		
H =	2.5	250 kg	250 kg
	2.9	120 kg	

A = 51 mm			
B =	<52 cm	≥ 52 cm	
C =	Max. 1.25 metres		
H =	2.5	250 kg	250 kg
	2.9	120 kg	

Regardless of the pipe-rail system above, our requirement is that a maximum support spacing (C) of 1 metre is applied in the last 10 meters!

---

## 11. EC DECLARATION OF CONFORMITY

(according to Annex IIA of the Machinery Directive)

**Berg Hortimotive**  
**Burg. Crezeelaan 42a**  
**2678 KZ De Lier - Holland**  
**T: +31 (0)174 – 517700**  
**www.berghortimotive.com**

While taking full responsibility, hereby declares that the product:

- ***Pipe-rail trolley type BeNomic Star 300 with double hydraulic scissors and hydraulic lift-wheels to 2.9 metres height***

**Article number: 5810. . . . .**

**Serial number: .....**

- Meets the requirements of the Machinery Directive 2006/42/EC

**Satisfies the following other EC directives:**

- Electromagnetic Compatibility Directive (EMC) 2014/30/EU (as recently amended)

*De Lier, The Netherlands, date .....-.....-.....*

*Signature of managing board or authorised signatory. ....*



## Appendix 2: TECHNICAL DRAWINGS

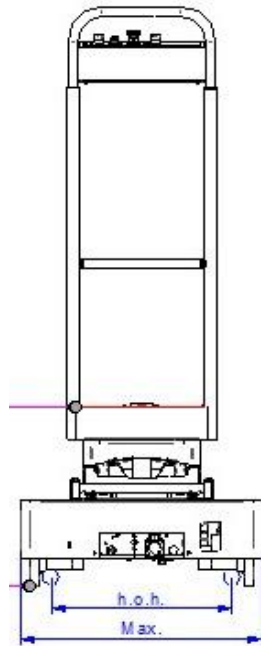

Fig. 2.1; Width dimensions in mm, 2 scissors

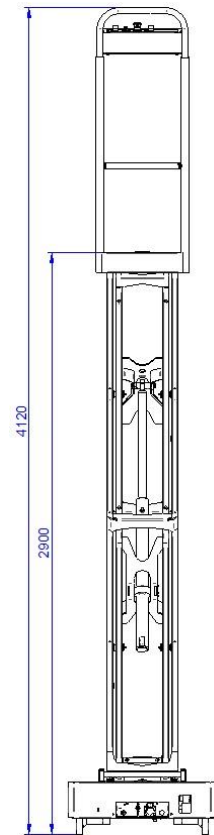

Fig. 2.2; Maximum height dimensions in mm, 2 scissors

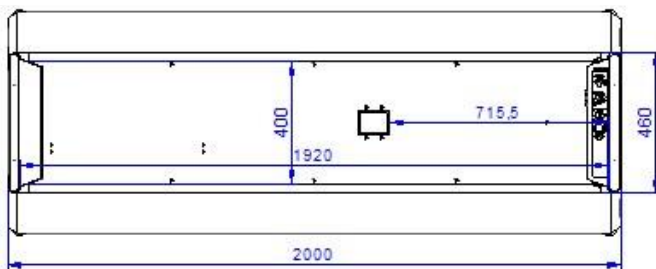

Fig. 2.4; Platform dimensions in mm, 2 scissors

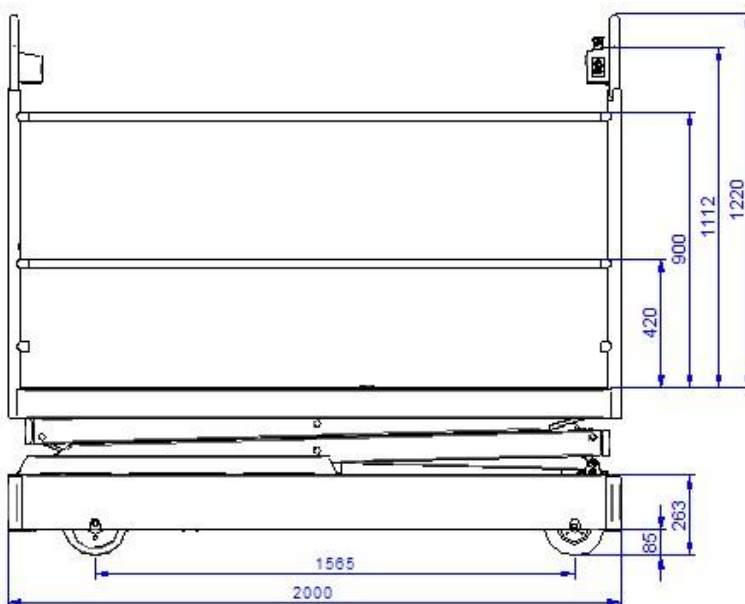

Fig. 2.5; Length dimensions in mm, 2 scissors

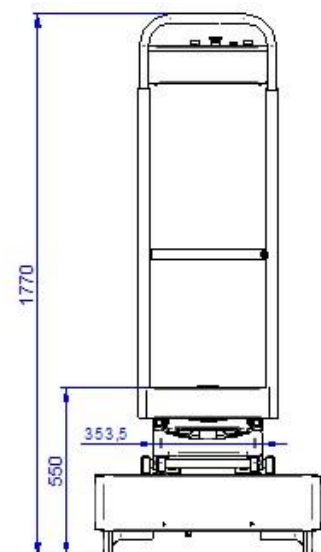

Fig. 2.3; Minimum height dimensions in mm, 2 scissors

## Appendix 3: Battery safety sheet

### Battery advice

The following chapter gives advice on efficient use, safety and maintenance.

### Efficient use of the pipe-rail trolley and batteries

The following recommendations are made to improve the life-cycle of the batteries of the pipe-rail trolley.

#### Basic principles:

- The battery goes flat sooner when running at higher speeds.
- High levels of starting and stopping increase electrical energy consumption.
- Through using the pipe-rail trolley, the remaining capacity and battery voltage gradually reduces, while simultaneously the current consumption increases. This results in increasing heat generation from the motor and speed regulator as the batteries gradually lose their charge.
- Worn rollers, or rollers with wound string, and rusty chains (poor maintenance) all result in higher energy consumption. (for maintenance instructions, visit our website: <http://www.berghortimotive.com/service/bsa-film>)
- Allowing batteries to go (completely) flat also reduces the life-span.
- Charging when required and good maintenance help to increase the life-cycle of the batteries.
- Charging when required also lowers the generation of heat in the motor and speed regulator, as well as the battery charger.

#### Efficient usage:

- Adjust the driving speed as much as possible to the working speed (potentiometer)
- By following the above recommendations, the productivity of the workers will increase too.

#### Safe use of the batteries

Below are some recommendations for use and maintenance.

#### WARNING!



- **When charging the batteries, an explosive gas is formed: fire, naked flame and smoking is prohibited!**
- **Only charge in properly ventilated spaces using a suitable charger!**
- **The fluid level must be checked every month! The battery fluid must be at least 1 cm higher than the plates.**
- **Only replenish using distilled (demineralised) water (use gloves)!**
- **Always replenish the batteries AFTER charging and never fill above the level mark at the battery cell filler hole (also see the traction battery instruction sheet).**

Discharging for more than 20% adversely affects the lifespan of the batteries and charger. Charge the batteries when the battery status meter shows 1–2 illuminated LEDs, this will benefit the lifespan of the batteries, the motor and the drive control! Always charge an empty battery immediately, this will significantly benefit the lifespan. So, preferably check the acid concentration every week, but check at least every month with a hydrometer (fig. A+B and table below).

With fully charged batteries, the specific mass (SM) should be 1280 g/l:

100%	Density 1280 g/l	=	12.7 volt
80%	1240		12.5
60%	1210		12.3
40%	1170		12.1
20%	1140		11.9

Switch off the *pipe-rail trolley*, at the main switch, before charging. When about to charge, always first connect the batteries to the charger, and afterwards switch on the charger. When charging is complete, first switch off the charger, then disconnect the battery.

Charging the batteries 'too much' can cause damage to the batteries because the battery fluid will boil for a longer period of time.

The use of a modern battery charger with automatic cut-off is recommended. This charger is available at Berg Hortimotive. **Only use a charger that is suitable for the batteries used! (see charger instructions)**

Never interrupt the charging process, completely finish charging, see indication on charger.

#### **WARNING! Danger of injury with the batteries:**

Avoid the battery fluid (electrolyte) coming into contact with skin. Wear safety goggles and gloves as battery acid is highly corrosive. Wash with soap and water if contact is made. If it comes into contact with the eyes, immediately rinse with running water for a period of at least five minutes and call for medical assistance. Always ensure there is sufficient soap and water in the vicinity and that assistance is within calling distance when people have to work near batteries. Avoid short circuits (sparks), and ensure that there is no electrical connection between the battery poles. The battery cover must be free of damage. Bare patches or dents can cause short circuits!

Explosive gas is released when the batteries are being charged. Keep sparks, open flames or cigarettes away from batteries.

Do not repair, clean or carry out other activities on the pipe-rail trolley while charging.

Before uninstalling the batteries, always switch off all current consumption items, to avoid sparks.

Ensure that the place where batteries are charged and/or stored is well ventilated. Ensure that no metal objects can fall on the batteries, as this could cause short circuits or sparks which could lead to an explosion.

Remove all personal objects including rings, bracelets, necklaces and wristwatches when working in the vicinity of batteries, because, for example, a short circuit could melt a ring resulting in serious burns.

When dismantling the battery, first disconnect the ground cable (-). When mounting, connect the ground cable (black) last of all.

#### **WARNING!**

**Always connect the plus (+ = red) to the plus terminal and minus (- = blue) to the negative terminal.**

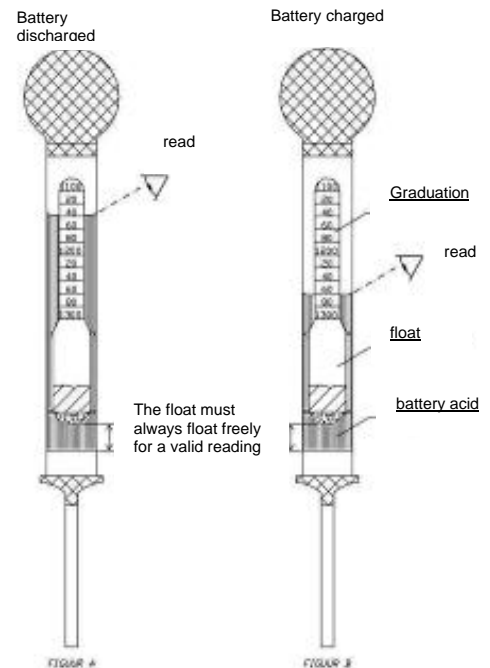

**Remark**

Check how many battery chargers you can connect to one circuit. You can check this by multiplying the number of amperes of the fuse with the voltage. E.g.:  $16\text{ A} \cdot 230\text{ V} = 3680\text{ W}$

Subsequently check the battery charger power rating. Divide the total power by the battery charger's power. E.g.:  $3680/500 = 7.36$ . In this case, seven battery chargers can be connected.

Also check that the voltage at the charging location corresponds with the voltage indicated on the battery charger. There may be voltage loss with long cables. If this is the case, you should consult your installer.

Check that it is the correct charger for your machine. The battery specifications that can be used with the charger are indicated on the charger or in the user manual!

	TREM-CARD	<b>UN 2794</b>
---	-----------	----------------

**Substance Batteries wet, filled with acid, electrical storage**

**UN Number 27**

**HIN 80**

**ADR Label 8**

**ADR Class 8**

**Packing group -**

**Emergency Response Information****CORROSIVE SUBSTANCE****1. Characteristics**

- Corrosive, causing damage to skin, eyes and air passages.
- Not flammable.

**2. Hazards**

- Heating of container(s) will cause pressure rise with risk of bursting and subsequent explosion (BLEVE).
- Gives off corrosive and irritant fumes, also when burning.
- May attack metals and produce hydrogen gas which may form explosive mixture with air.
- The vapour may be invisible and is heavier than air. It spreads along the ground and may enter sewers and basements.

**3. Personal protection**

- Chemical protection suit.
- Respiratory mask equipped with ABEKP1 filter.



## **4. Intervention actions**

### **4.1 General**

- Keep upwind. Put on protective equipment before entering danger area.

### **4.2 Spillage**

- Stop leaks if possible.
- Dilute spillage with water spray as far as necessary to reduce hazard. Contain run off by any means available.
- If substance has entered a water course or sewer, inform the responsible authority.
- Ventilate sewers and basements where there is no risk to personnel or public.

### **4.3 Fire (involving the substance)**

- Keep container(s) cool with water.
- Extinguish with water fog (spray).
- Do not use water jet to extinguish.
- Use water spray to knock down fire fumes if possible.
- Avoid unnecessary run-off of extinguishing media which may cause pollution.

## **5. First aid**

- If substance has got into eyes, rinse eyes with water for at least 15 minutes and seek immediate medical attention.
- Remove contaminated clothing immediately and drench affected skin with plenty of water.
- Persons who have been in contact with the substance or have inhaled fumes should get immediate medical attention. Pass on all available product information.
- Mouth to mouth resuscitation should be avoided. Use alternative methods, preferably with oxygen or compressed air driven apparatus.

## **6. Essential precautions for product recovery**

- Use acid resistant equipment.
- Recover spilled product in vented container fitted with absorption filter.

## **7. Precautions after intervention**

### **7.1 Undressing**

- Drench contaminated suit and breathing apparatus with water before removing face mask and suit.
- Use chemical protection suit and self-contained breathing apparatus while undressing contaminated co-workers or handling contaminated equipment.

### **7.2 Equipment clean up**

- Drench with water before transporting from incident.





# INSTRUCTIONS TRACTION BLOCKS



## Daily maintenance EW159T:

- Only discharge the battery to 80% maximum (Electrolyte level 1130 SG)
- Connect the battery to the charger, switch on charger and charging should start automatically
- Do not disconnect the battery until charge cycle has finished
- When charge cycle has completed make sure charger is switched off before disconnecting the DC plug

## Weekly maintenance EW159T:

- Check the level of the Electrolyte on the battery  
Only top up battery with demineralised water
- Only top up after charge cycle has completed
- The battery should only need topping up every 2 weeks
- If required more frequently please contact the manufacturer
- Check for signs of corrosion on cables or bolts clean as required
- The battery tops should be kept clean and dry  
No smoking or naked flames to be in the area of charging

Only top up the battery after the charging cycle has been completed to avoid electrolyte spilling from the battery!  
No smoking or naked flames to be in the area of charging.

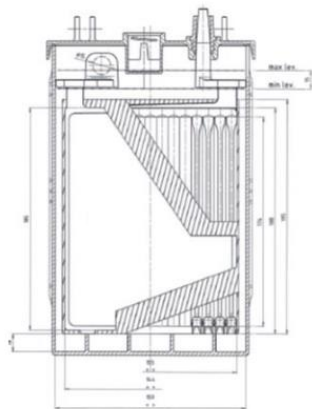

Green is maximum level

Red is minimum level



Always follow the manufacturer's instructions



No smoking or naked flames



Electrical Hazard



Danger risk of explosion



Always wear the correct PPE



Avoid contact of skin and eyes



Room must be well ventilated



All disused batteries must be recycled

## Appendix 4: Cleaning the powder coat finish

### The importance of cleaning and maintenance:

- The product's appearance and finish are maintained for longer.
- Its service life is extended.
- Helps to resist corrosion.
- It prevents the spreading of plant diseases.
- Encourages employees to handle machines carefully.

By cleaning properly periodically, it prevents the chemicals present from damaging the powder coat finish. Protective layers are sensitive to acids, salts and other aggressive substances and age faster if contaminated. In addition, thick layers of dirt can absorb and hold more moisture, which can increase the aggressive impact on the protective layer.

### The cleaning frequency depends on:

- The level of contamination is cultivation related.
- Product type, used between crop or, for example, only on concrete paths.
- Exposure to chemical liquids (spraying equipment).
- Exposure to chemical vapours (space treatments in greenhouses).
- Exposure to sun and UV radiation.
- Humidity and condensation.

The above items give a load factor that is dependent on usage. If applicable, the following cleaning schedule should be followed.

### When to clean:

- |  |                               |
|--|-------------------------------|
| • Plant and product residues.                            | daily                         |
| • Soil and sand.   | Twice per week                |
| • Glass, rope, plastic, elastic, clips, wire hooks, etc. | Twice per week                |
| • Chemical exposure.                                     | Clean immediately after use   |
| • Dull and contaminated surface finish.                  | Periodically, after detection |

### How to clean:

- Remove contamination on the paint surface or with tool (soft brush or cloth) or compressed air (<6 bar!).
- After chemical exposure, remove contamination with coarse sponge or soft cloth soaked in tap water.
- Clean dull and contaminated paint with neutral detergent with pH between 5 and 8 (see cleaning agent label) and sponge or soft cloth.
- **Tip** – If a cleaning agent is used for the first time, we recommend testing it on a sample piece before cleaning the entire machine.

### What you should definitely not do:



- Never clean powder coatings with abrasive or polishing cleaning agents.
- Do not use a tool with abrasive surface (steel wool, scouring pads, etc.).
- Hard pushing, brushing, scrubbing etc. is not permitted.
- Do not use organic solvents to clean or preserve the powder coat paint.
- Pouring water, using a water hose or high-pressure washer can cause damage.

### After cleaning:

- Make sure all the cleaned surfaces are able to dry properly, temporarily loosen overlapping shield covers.
- Lubricate pivot points that have come into contact with cleaning agents, doing so according to the recommendations in the maintenance schedule of the User Manual.
- Repair any damage to the powder coat with a suitable paint.

### Attention!

The **recommendations** above are the responsibilities of the party responsible for carrying out the cleaning. If you have any questions regarding the cleaning product to be used, please consult the manufacturer.